

C.O.B. Mon. #22
 S 42°32'28" W
 2627.89'

HATCHED AREA DENOTES
 0.0446 ACRES OF R.O.W. TO
 BE DEDICATED WITH PLAT

WOODVILLE ROAD
 24' Asphalt - 70' R.O.W.

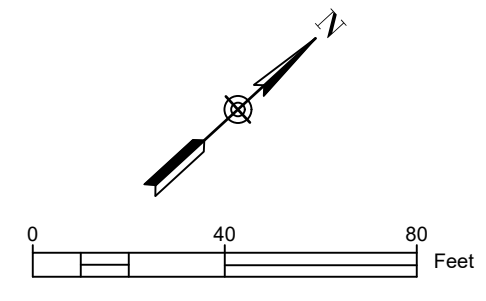

Curve Table					
Curve #	Length	Radius	Delta	Chord Direction	Chord Length
C1	9.47	75.00	7.23	N51° 29' 49"W	9.46
C2	22.97	25.00	52.65	N74° 15' 26"W	22.17
C3	15.90	25.00	36.45	S61° 11' 36"W	15.64
C4	39.46	25.00	90.43	N2° 40' 05"W	35.49
C5	37.61	25.02	86.11	N85° 38' 52"E	34.17
C6	41.16	25.00	94.33	S4° 07' 32"E	36.67
C7	38.87	25.00	89.08	S87° 34' 48"W	35.07
C8	37.89	75.00	28.95	N69° 35' 14"W	37.49
C9	37.89	75.00	28.95	S81° 27' 51"W	37.49
C10	31.35	75.00	23.95	S55° 00' 53"W	31.12
C11	37.40	25.00	85.71	S85° 53' 45"W	34.01
C12	40.63	25.00	93.11	N4° 41' 35"W	36.30
C13	21.03	25.00	48.19	S67° 08' 11"W	20.41
C14	24.56	50.00	26.14	S77° 09' 33"W	24.31
C15	42.16	50.00	48.32	S38° 55' 45"W	40.93
C16	39.77	50.00	45.57	S8° 00' 55"E	38.73
C17	36.81	50.00	42.18	S51° 53' 36"E	35.99
C18	43.71	50.00	50.08	N81° 58' 27"E	42.33
C19	51.22	50.00	58.69	S27° 35' 15"W	49.01
C20	2.96	50.00	3.39	S3° 27' 12"E	2.96
C21	21.03	25.00	48.19	N18° 56' 48"E	20.41
C22	61.88	75.00	47.27	N18° 13' 37"E	60.14
C23	37.90	75.00	28.96	N19° 53' 15"W	37.50
C24	22.10	75.00	16.88	N42° 48' 26"W	22.02

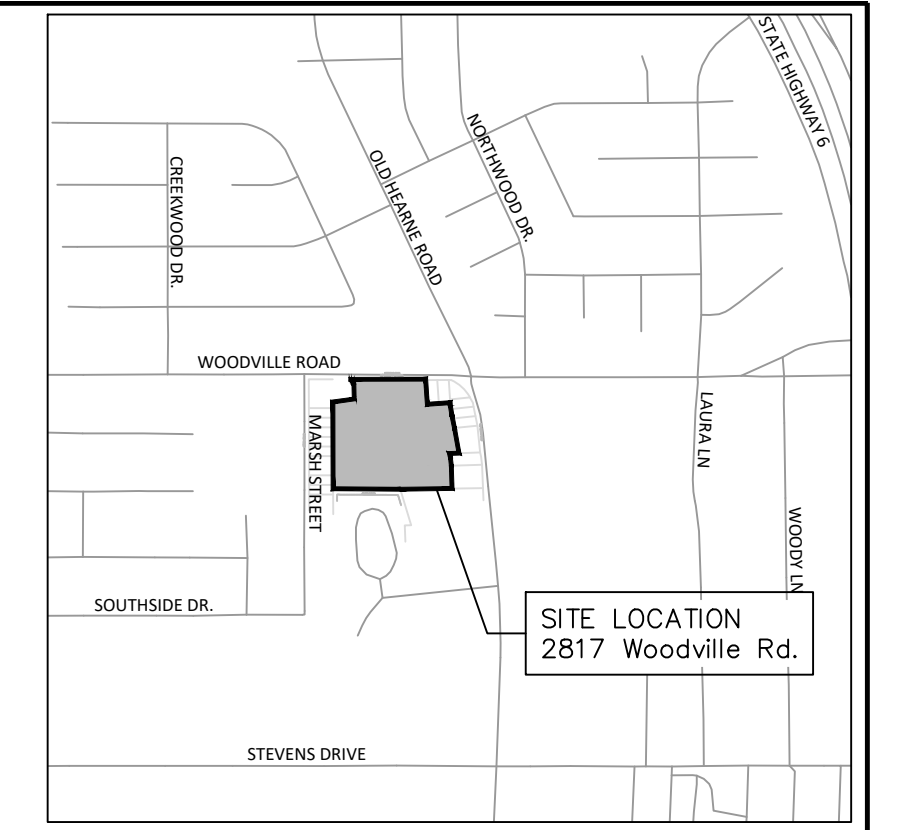

LOCATION MAP
 SCALE: 1" = 1000'

Line Table		
Line #	Length	Direction
L1	16.96	S51° 14' 01"E
L2	16.60	S56° 22' 03"E
L3	34.26	S56° 16' 17"E
L4	15.82	S57° 58' 38"E
L5	50.12	S58° 45' 34"E
L6	50.02	S40° 46' 38"W
L7	22.39	S60° 57' 38"E
L8	42.27	S54° 03' 47"E
L9	37.44	N47° 52' 52"W
L10	30.72	N47° 52' 52"W
L11	8.65	S43° 02' 49"W

MARSH STREET

OLD HEARNE ROAD

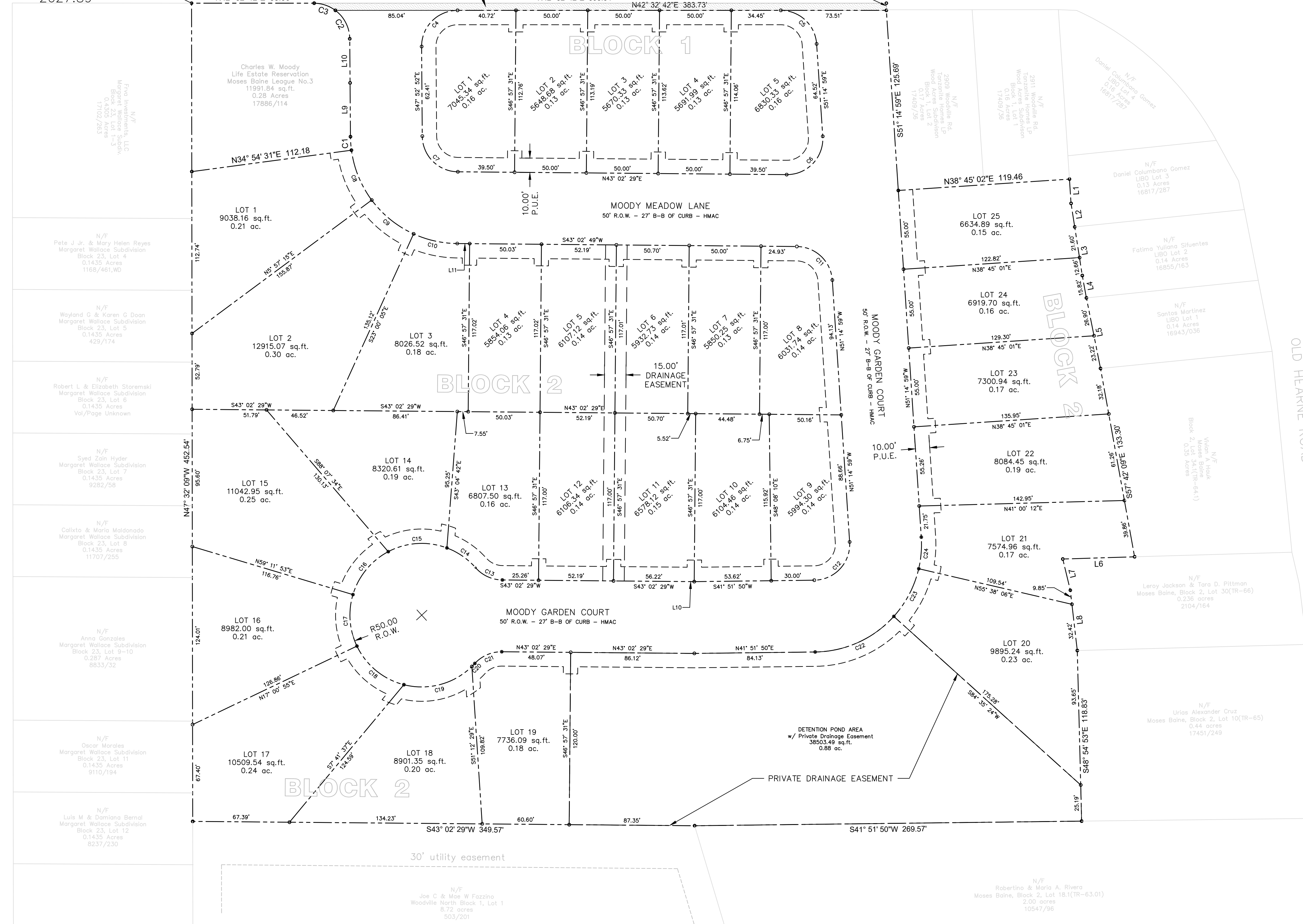

FINAL PLAT

WOODVILLE ESTATES

LOTS 1 - 5, BLOCK 1
 LOTS 1 - 25, BLOCK 2

30 TOTAL LOTS

7.49 acres of the
 Moses Baine League, Abstract No.3,
 Block 2, Lot 28 (TR-68)
 Bryan, Brazos County, Texas

OCTOBER 5, 2022

OWNER/DEVELOPER
 BLUE BURRO MANAGEMENT, LLC.
 2014 CEDARWOOD DRIVE
 BRYAN, TEXAS 77807
 254-313-7837

SURVEYOR
 TUMLINSON LAND SURVEYING
 P.O. BOX 633
 MILLICAN, TEXAS 77866
 254-931-6707

ENGINEER
 JBS ENGINEERING & ENVIRONMENTAL, LLC.
 2129 E. WILLIAM J. BRYAN PKWY.
 BRYAN, TX 77802
 979-485-2879



Certificate of ownership and dedication.

STATE OF TEXAS
COUNTY OF BRAZOS

I (We), _____, the owner(s) and developer(s) of the land shown on this plat, being (part of) the tract of land as conveyed to me (us, it) in the Deeds Records of Brazos County in Volume _____, Page _____, and whose name is subscribed hereto, hereby dedicate to the use of the public forever all streets, alleys, parks, watercourses, drains, easements and public places hereon shown for the purposes identified.

_____ Owner

STATE OF TEXAS
COUNTY OF BRAZOS

Before me, the undersigned authority, on this day personally appeared _____, known to me to be the person(s) whose name(s) is/are subscribed to the foregoing instrument, and acknowledged to me that he or she executed the same for the purpose stated.

Given under my hand and seal of office this _____ day of _____, 20_____.

_____ Notary Public, Brazos County, Texas

Certification of the surveyor.

STATE OF TEXAS
COUNTY OF BRAZOS

I, Tyler Tumlinson, Registered Professional Land Surveyor No. 6410, in the State of Texas, hereby certify that this plat is true and correct and was prepared from an actual survey of the property and that property markers and monuments were placed under my supervision on the ground, and that the metes and bounds describing said subdivision describes a closed geometric form.

_____ Registered Professional Land Surveyor, #6410

Certification by the county clerk.

STATE OF TEXAS
COUNTY OF BRAZOS

I, _____, County Clerk in and for said County, do hereby certify that this plat together with its certificates of authentication was filed for record in my office the _____ day of _____, 20_____, in the Official Records of Brazos County in Volume _____, Page _____.

_____ County Clerk Brazos County, Texas

Approval of the planning and zoning commission.

I, _____, Chair of the Planning and Zoning Commission of the City of Bryan, State of Texas, hereby certify that the attached plat was duly filed for approval with the Planning and Zoning Commission of the City of Bryan on the _____ day of _____, 20_____, and same was duly approved on the _____ day of _____, 20_____ by said Commission.

_____ Chair, Planning & Zoning Commission Bryan, Texas

Approval of the city planner.

I, _____, the undersigned, City Planner and/or designated Secretary of the Planning and Zoning Commission of the City of Bryan, hereby certify that this plat is in compliance with the appropriate codes and ordinances of the City of Bryan and was approved on the _____ day of _____, 20_____.

_____ City Planner, Bryan, Texas

Approval of the city engineer.

I, _____, the undersigned, City Engineer of the City of Bryan, hereby certify that this plat is in compliance with the appropriate codes and ordinances of the City of Bryan and was approved on the _____ day of _____, 20_____.

_____ City Engineer, Bryan, Texas

METES AND BOUNDS DESCRIPTION

7.53 ACRE TRACT
Moses Baine League
A-3
Brazos County, Texas

Being a 7.53 acre tract of land out of the Moses Baine League, Abstract No. 3, Brazos County, Texas and being part of that certain called 7.43 acre tract of land described to Charles W. Moody, recorded in Volume 360, Page 783 of the Deed Records of Brazos County, Texas, and being all that certain called 1.00 acre tract described in an Affidavit of Heirship recorded in Volume 11650, Page 13 of the Official Records of Brazos County, Texas, said 7.52 acres being more particularly described by metes and bounds as follows;

Commencing at a 1/2 inch iron rod found at the west corner of said 7.43 acre tract, located at the north corner of Lot 1, Block 23 of the Margaret Wallace Subdivision, also located on the southeast line of Woodville Road, for the west corner of this

Thence along the northwest line of said 7.43 acre, with the southeast line of Woodville Road N 42°32'42" E a distance of 85.36 feet to a 1/2 inch iron rod with yellow set for the northwest corner and POINT OF BEGINNING of this;

THENCE continuing along said northwest line, and Woodville Road N 42°32'42" E a distance of 398.21 feet to a 1/2 inch iron rod with yellow cap set for the western northwest corner of this;

THENCE along the northeast line of said 7.43 acre tract with a portion of Woodville Road and joining the southwest line of Lot 2 of Wood Acres, (17409/36), S 51°14'59" E a distance of 130.70 feet to a 1/2 inch iron rod with yellow cap set at the south corner of said Lot 2, for an interior lot corner of this;

THENCE along a northwestern line of said 7.43 acre tract and the remainder of the above mentioned 1.00 acre tract, with the southeast line of said Lot 2 and Lot 1 of said Wood Acres N 38°45'02" E a distance of 119.46 feet to a 1/2 inch iron rod with yellow cap set at the eastern northwest corner of said remainder tract, located at the east corner of said Lot 1, also located on the south line of Lot 2 of the Libo Subdivision, (15708/260), for the eastern northwest corner of this;

THENCE along the northeast line of said 1.00 acre tract with the southwest line of said Libo Subdivision, the following courses and distances:

L1 S 51°14'01" E a distance of 16.96 feet to a 1/2 inch iron rod with yellow cap set for an angle point,
L2 S 56°22'03" E a distance of 16.60 feet to a 1/2 inch iron rod found for an angle point,
L3 S 56°16'17" E a distance of 34.26 feet to a 1/2 inch iron rod with yellow cap set for an angle point,
L4 S 57°58'38" E a distance of 15.82 feet to a 1/2 inch iron rod with yellow cap set for an angle point, and
L5 S 58°45'34" E a distance of 50.12 feet to a 1/2 inch iron rod found at the south corner of Lot 4, also located at the west corner of a called 0.3598 acre tract to Vivian Ann Hauk, (316700), for an angle point,

THENCE continuing along the northeast line of said remainder tract, with the southwest line of said 0.3598 acre tract S 57°42'09" E a distance of 133.30 feet to a 1/2 inch iron rod found at the south corner of said 0.3598 acre tract, located on the northwest line of a called 0.236 acre tract to Leroy Jackson and Tara D. Pittman, (2104/164), for an external ell corner of this;

THENCE along the east line of said remainder and the northeast lines of said 7.43 acre tract, with the southwest lines of said 0.236 acre tract the following courses and distances:

S 40°46'38" W a distance of 50.02 feet to a 1/2 inch iron rod found at the west corner of said 0.236 acre tract for an interior ell corner,
L6 S 60°57'38" E a distance of 22.39 feet to a 1/2 inch iron rod found for an angle point, and
L7 S 54°03'47" E a distance of 42.27 feet to a 1/2 inch iron rod with yellow cap set at the south corner of said 0.236 acre tract, located at the west corner of a 160 foot by 140 foot tract to Urias Alexander Cruz, (17451/249), for an angle point of this;

THENCE continuing along said 7.43 acre tract, with the southwest line of said Cruz tract S 48°54'53" E a distance of 118.83 feet to a 1/2 inch iron rod with yellow cap set at the east corner of said 7.43 acre tract, located at the south corner of said Cruz tract, also located on the northwest line of a called 2 acre tract to Roberto Rivera and Maria A. Rivera, (10547/96), for the east corner of this;

THENCE along the southeast line of said 7.43 acre tract, with the northwest line of said 2 acre tract S 41°51'50" W a distance of 269.57 feet to a 3/8 inch iron rod found at the west corner of said 2 acre tract, located at a northwest corner of Woodville North Lot 1, Block One, (503/201), for an angle point of this;

THENCE continuing along said southeast line, with the northwest line of said Woodville North S 43°02'29" W a distance of 349.57 feet to a 1/2 inch iron rod with yellow cap set found at the south corner of said 7.43 acre tract, located at the west corner of said Woodville North, also located on the north line of Lot 12, Block 23 of said Margaret Wallace Subdivision, for the south corner of this;

THENCE along the southwest line of said 7.43 acre tract, with the north line of said Block 23 of the Margaret Wallace Subdivision N 47°32'09" W a distance of 452.54 feet to a 1/2 inch iron rod with yellow cap set for the southern southwest corner of this;

THENCE crossing said 7.43 acre tract the following courses and distances:

N 34°54'31" E a distance of 112.18 feet to a 1/2 inch iron rod with yellow cap set for a corner,
C1 With a curve to the right, having a radius of 75.00 feet, an arc length of 9.47 feet and a chord bearing N 51°29'49" W a distance of 9.46 feet to a 1/2 inch iron rod with yellow cap set for an angle point,
L8 N 47°52'52" W a distance of 37.44 feet to a 1/2 inch iron rod with yellow cap set for an angle point,
L9 N 47°52'52" W a distance of 30.72 feet to a 1/2 inch iron rod with yellow cap set for an angle point, and
C2 With a curve to the left, having a radius of 25.00 feet, an arc length of 38.88 feet, and a chord bearing S 87°31'07" W a distance of 35.08 feet to the POINT OF BEGINNING.

All bearings and distances are based on State Plane Coordinate System, Texas Central Zone, Nad 1983.

GENERAL NOTES:

1. THE PROJECT PROPERTIES ARE LOCATED IN THE CITY OF BRYAN.
2. THE PROJECT PROPERTY DOES NOT LIE WITHIN THE LIMITS OF THE 100-YEAR FLOOD HAZARD AREA AS ESTABLISHED BY THE FEDERAL EMERGENCY MANAGEMENT AGENCY: MAP NUMBER 48041C0185E (DATED MAY 16, 2012).
3. THE BUILDING SETBACK REQUIREMENTS FOR THIS TRACT ARE ESTABLISHED BY THE CITY OF BRYAN ORDINANCES SEC. 62-161.
4. THE METES AND BOUNDS DESCRIPTION SHOWN HEREIN WERE PROVIDED BY TUMLINSON LAND SURVEYING, DATED MARCH 30, 2022.
7. SANITARY SEWER: SANITARY SEWER SERVICE FOR THIS SUBDIVISION SHALL BE PROVIDED BY THE EXISTING CITY OF BRYAN SANITARY SEWER INFRASTRUCTURE ALONG WOODVILLE ROAD. 979-209-5900
8. DOMESTIC WATER SERVICE: THE DOMESTIC WATER SERVICE FOR THIS SUBDIVISION SHALL BE PROVIDED BY THE EXISTING CITY OF BRYAN WATER MAIN INFRASTRUCTURE ALONG WOODVILLE ROAD. 979-209-5900
9. ELECTRICAL SERVICE: BRYAN TEXAS UTILITIES (BTU) SHALL BE PROVIDING ELECTRICAL SERVICE TO THIS SUBDIVISION. WHERE ELECTRICAL FACILITIES ARE INSTALLED, BTU HAS THE RIGHT TO INSTALL, OPERATE, RELOCATE, CONSTRUCT, RECONSTRUCT, ADD TO, MAINTAIN, INSPECT, PATROL, ENLARGED, REPAIR, REMOVE AND REPLACE SAID FACILITIES UPON, OVER, UNDER, AND ACROSS THE PROPERTY INCLUDED IN THE P.U.E., AND THE RIGHT OF INGRESS AND EGRESS ON PROPERTY ADJACENT TO THE P.U.E. TO ACCESS ELECTRIC FACILITIES. 979-821-5784
10. ALL PUBLIC UTILITY EASEMENTS (PUE) SHOWN HEREON SHALL BE DEDICATED WITH THE PLATTING OF THIS SUBDIVISION.
11. DRIVEWAYS WILL BE LOCATED AND CONSTRUCTED IN ACCORDANCE WITH BCS GUIDELINES.
12. ALL DEVELOPMENT AND CONSTRUCTION SHALL BE IN ACCORDANCE WITH THE CITY OF BRYAN STANDARDS, ORDINANCES AND REGULATIONS.
13. THE CITY OF BRYAN IS RESPONSIBLE FOR THE MAINTENANCE OF PUBLIC INFRASTRUCTURE WITHIN THE RIGHT-OF-WAY AND PUBLIC UTILITY EASEMENTS.
14. SUBDIVISION'S HOMEOWNER'S ASSOCIATION (HOA) IS RESPONSIBLE FOR MAINTENANCE OF PRIVATE DRAINAGE EASEMENTS, INCLUDING STORM SEWER, DRAINAGE WAYS, DETENTION AREAS AND LANDSCAPE AREAS. THE CITY OF BRYAN SHALL NOT BE RESPONSIBLE FOR ANY OPERATION, REPAIR, AND MAINTENANCE OF THESE AREAS.
15. ALL LOTS WITH FRONTAGE ON WOODVILLE ROAD WILL NOT BE ALLOWED TO ACCESS PROPERTY FROM WOODVILLE ROAD AND MUST USE WOODY MEADOW LANE FOR ACCESS.

FINAL PLAT

WOODVILLE ESTATES

LOTS 1 - 5, BLOCK 1
LOTS 1 - 25, BLOCK 2

30 TOTAL LOTS

7.49 acres of the
Moses Baine League, Abstract No.3,
Block 2, Lot 28 (TR-68)
Bryan, Brazos County, Texas

OCTOBER 5, 2022

OWNER/DEVELOPER
BLUE BURRO MANAGEMENT, LLC.
2014 CEDARWOOD DRIVE
BRYAN, TEXAS 77807
254-313-7837

SURVEYOR
TUMLINSON LAND SURVEYING
P.O. BOX 633
MILLICAN, TEXAS 77866
979-485-6707

ENGINEER
JBS ENGINEERING & ENVIRONMENTAL, LLC.
2129 E. WILLIAM J. BRYAN PKWY.
BRYAN, TX 77802
979-485-2879